



CMMI-10-PCA

Microphone Input Transformer 1 : 10 Step-up

- \$ Recommended for high impedance F.E.T. and tube amplifiers
- \$ Very Good Bandwidth
- \$ Very Good CMRR: 102 dB at 60 Hz
- \$ +19.75 dB nominal voltage step-up
- \$ Low profile package; pc mount

The CineMag CMMI-10-PCA is a p.c. mount microphone input transformer which follows classic designs. It is best used with high input impedance amplifiers. This transformer exhibits good bandwidth, common mode rejection ratio (CMRR), and distortion characteristics. The CMMI-10-PCA is a small, cost-effective p.c. mount solution and is widely used in professional grade designs. It is encased in a μ Metal can which provides 30 dB of magnetic shielding. As with all CineMag transformers, the wires from the internal foil shields between windings are spot welded for maximum long term reliability.

This transformer has a moderately high impedance secondary. Care must be exercised in the design of the amplifier that it drives to obtain best results and to realize good bandwidth.

CMMI-10-PCA

Parameter	Conditions	Typ
Turns Ratio		1 : 10.00
Voltage Gain	1 kHz, -20 dBu 150 Ω input, 100K secondary load impedance	19.75 dB
Distortion (THD+N%)	1 kHz, -2 dBu Test circuit 1 20 Hz, -20 dBu Test circuit 1	0.002% 0.06%
Max 20 Hz input level	1.0% THD; Test Circuit 1	-2 dB
Response, ref 1 kHz	20 Hz Test Circuit 1 20 kHz Test Circuit 1 -3 dB	-0.35 dB +0.2 dB 90 kHz
Phase Shift at 20 Hz Phase Shift at 20 kHz	Referenced to source generator Test Circuit 1	+2° -10°
CMRR	60 Hz Test Circuit 2 per IEE Std 389-1996 ¶19 1 kHz Test Circuit 2 per IEE Std 389-1996 ¶19	102 dB 78 dB
Operating Temp Range	Operation and storage	0° C Min 70° C Max
Max Soldering Temp (p.c.)	10 Seconds	270° C Max

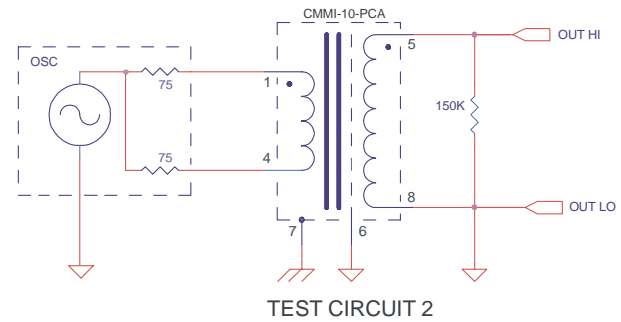
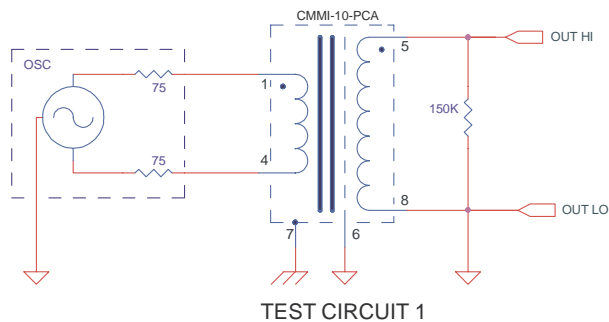
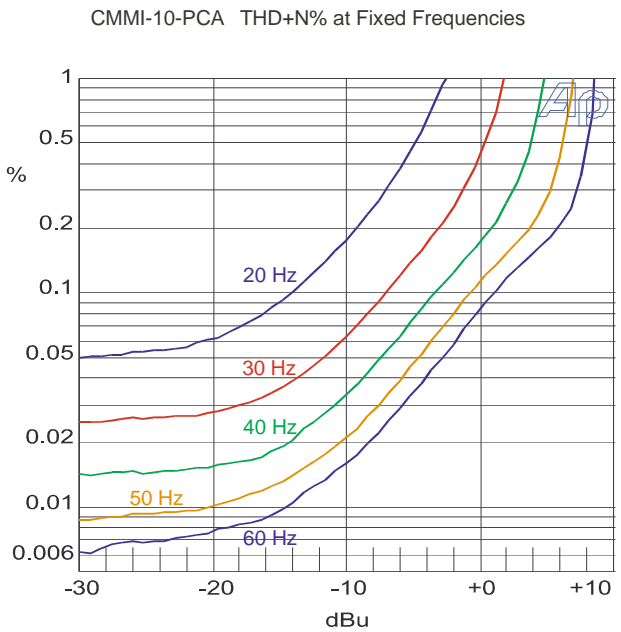
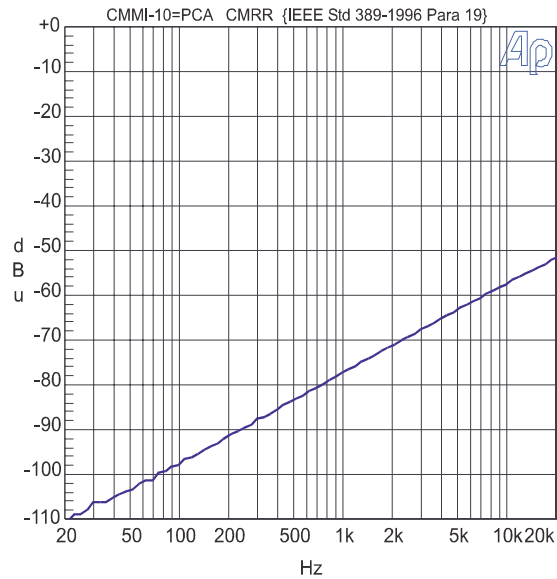
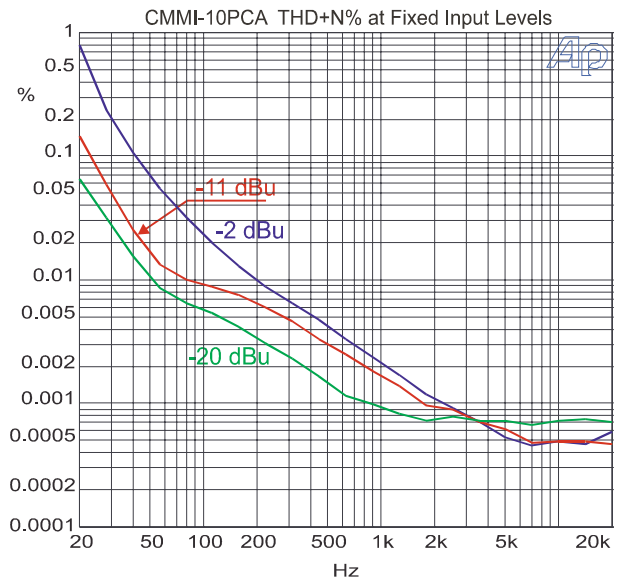
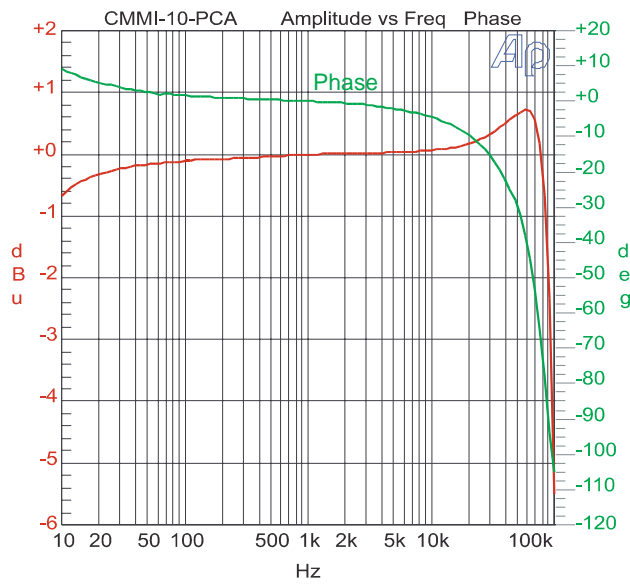

NOTES:

1. All graphs generated from one (1) randomly chosen device. No statistical averaging or weighting. Data from one sweep.

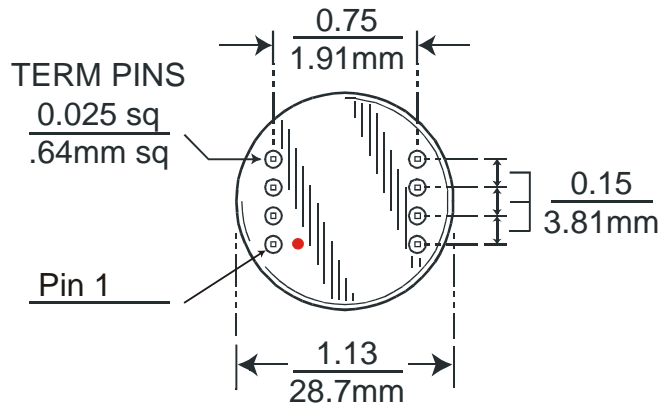
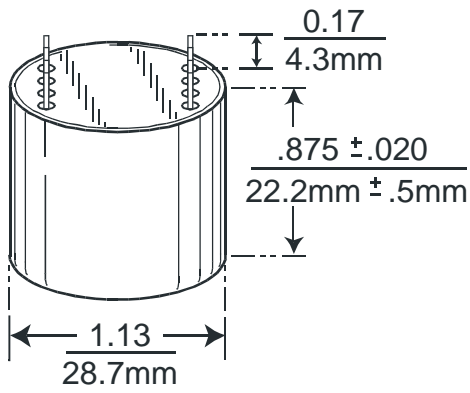

Bottom View