



Superior Magnetics Since 1979

## CMMI-7C

**Microphone Input Transformer**  
**200Ω Primary with 50Ω tap - 1 : 7 Step-up**

- **Good for bipolar transistor, F.E.T., and tube amplifiers**
- **Split primary for 50Ω or 200 Ω sources**
- **Very good bandwidth (- 1/3 dB at 50 kHz)**
- **Good CMRR: 85 dB at 60 Hz**
- **0.05% THD at -10dB input level**
- **+17 dB step-up Zin=200Ω**
- **+22 dB step-up Zin=50Ω**

The CineMag CMMI-7C microphone input transformer was engineered for the audio engineer desiring to feed a mic preamp with both 200Ω and 50 Ω microphones. Being designed for a 97.6K load on the secondary, it works well for both moderate input impedance amplifiers as well as high impedance devices. This transformer exhibits very good bandwidth, good common mode rejection ratio (CMRR), and good distortion characteristics. It is encased in a  $\mu$ Metal can which provides 30 dB of magnetic shielding and is available with either a threaded boss or screw mounting studs. As with all CineMag transformers, the wires from the internal foil shields between windings are all spot welded for maximum long term reliability. The CMMI-7C is available both in p.c. mount package and with wire leads.

This transformer has a moderately high impedance secondary. Care must be exercised in the design of the amplifier that it drives to obtain best results and to realize good bandwidth.

**CMMI-7C / CMMI-7C-PC**

Parameter	Conditions	Typ
Turns Ratio		1 : 7.00
Voltage Gain	1 kHz, -20 dBu 50Ω input, 97.6K secondary load impedance	+22 dB
	1 kHz, -20 dBu 200Ω input, 97.6K secondary load impedance	+17 dB
Distortion (THD+N%)	1 kHz, +8 dBu                      Test Circuit 1	0.0015%
	20 Hz, -4 dBu                        Test Circuit 1	0.08
Max 20 Hz input level	1.0% THD;                            Test Circuit 1	+7 dB
Response, ref 1 kHz	20 Hz    Rs=200                        Test Circuit 1	-0.1 dB
	20 kHz   Rs=200                        Test Circuit 1	+0.1 dB
	-3 dB	160 kHz
Phase Shift at 20 Hz Phase Shift at 20 kHz	Referenced to source generator	+3°
	Rs=200                                    Test Circuit 1	-8°
CMRR	60 Hz Test Circuit 3 per IEEE Std 389-1996 ¶19	85 dB
	1 kHz Test Circuit 3 per IEEE Std 389-1996 ¶19	70 dB
Operating Temp Range	Operation and storage	0° C Min                      70° C Max
Max Soldering Temp (p.c.)	10 Seconds	270° C Max

9050 Independence Ave. Canoga Park, California 91304    ☎(818) 993-4644    ☒ (818) 993-4604    <http://www.cinemag.biz>

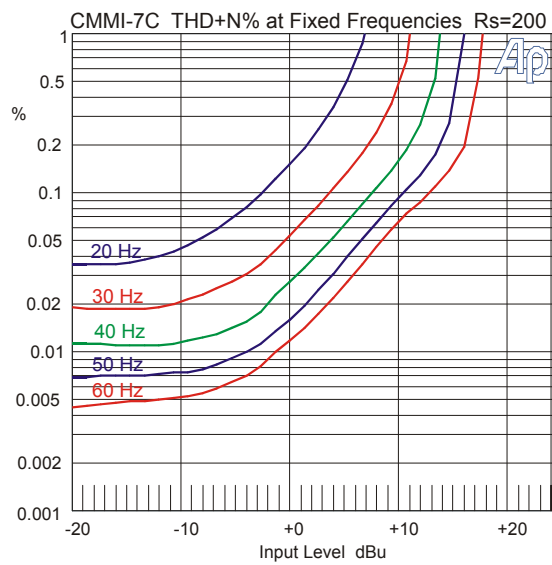
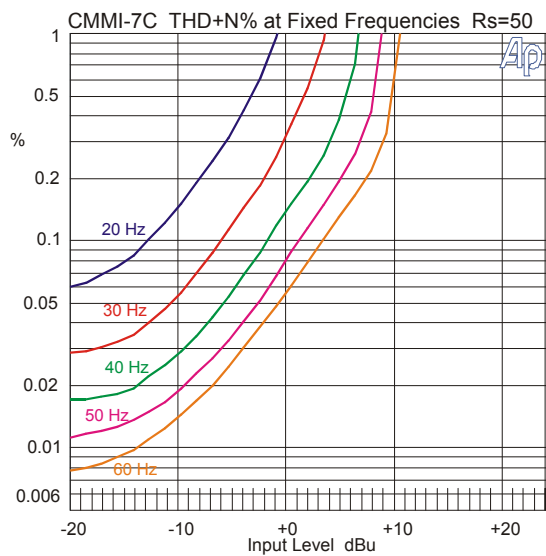
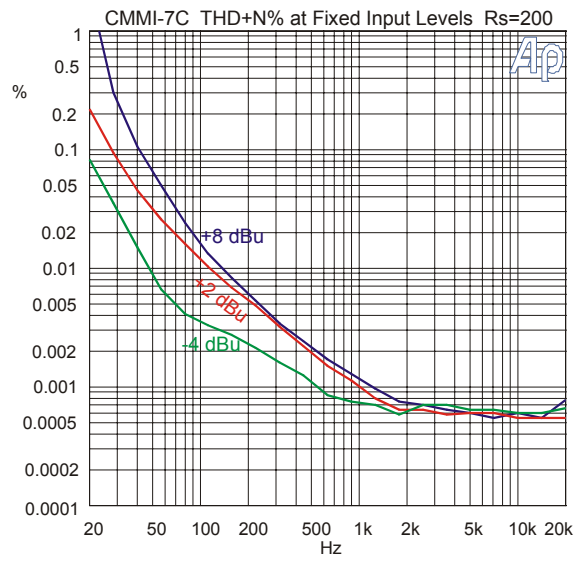
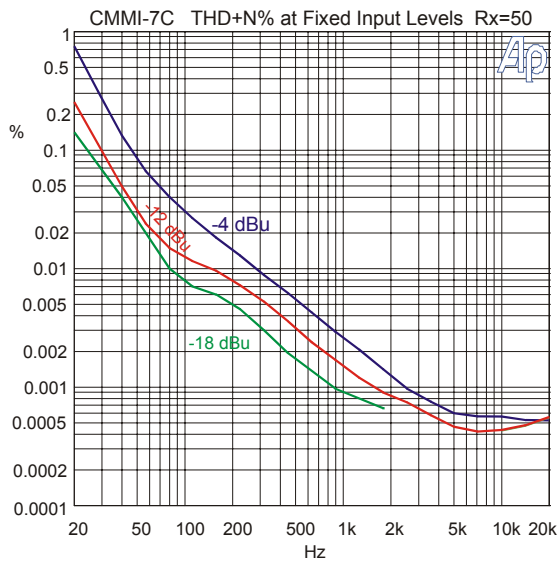
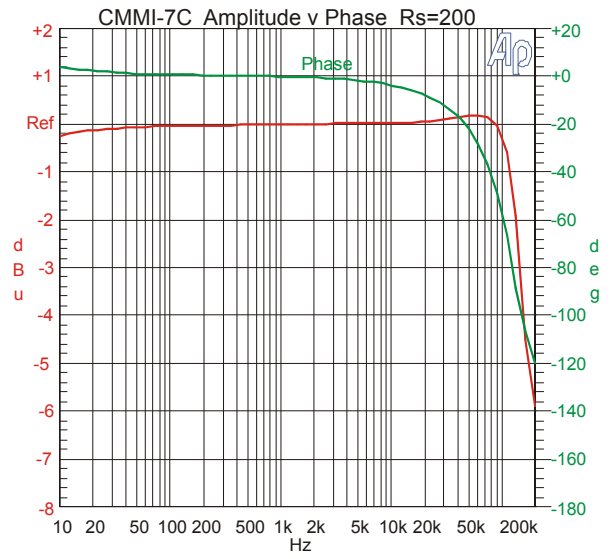
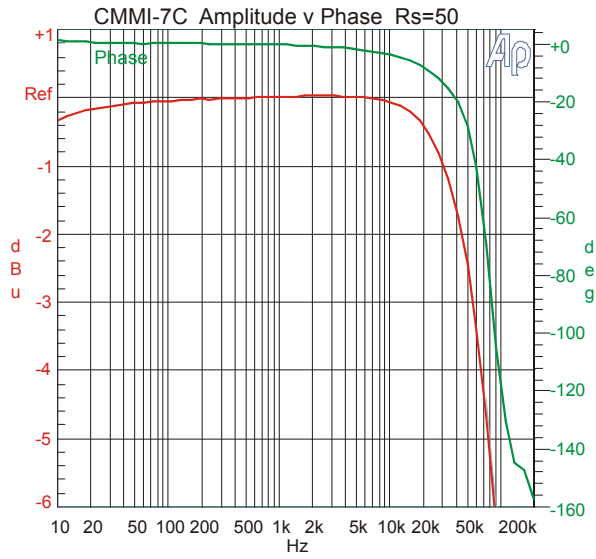

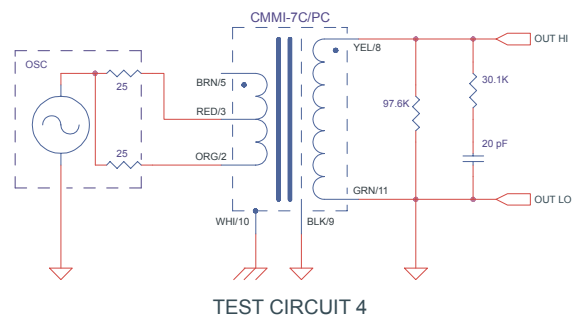
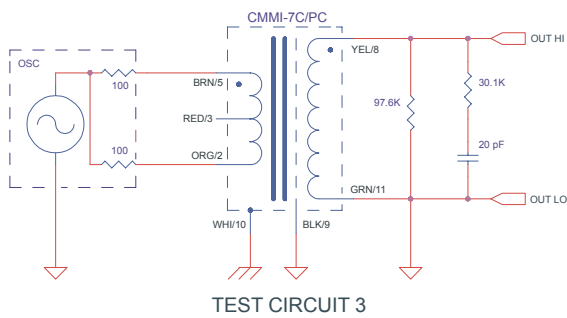
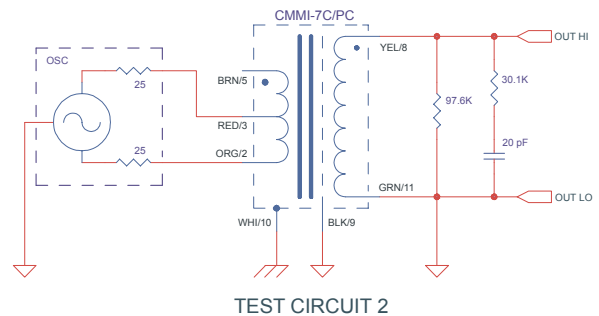
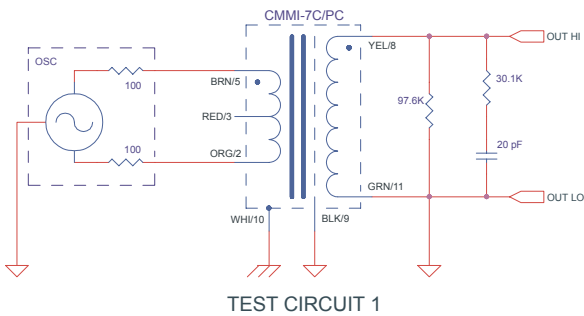
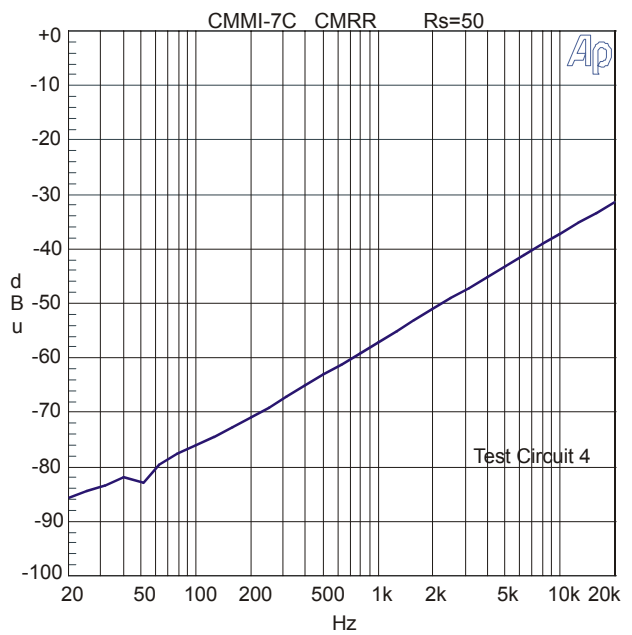
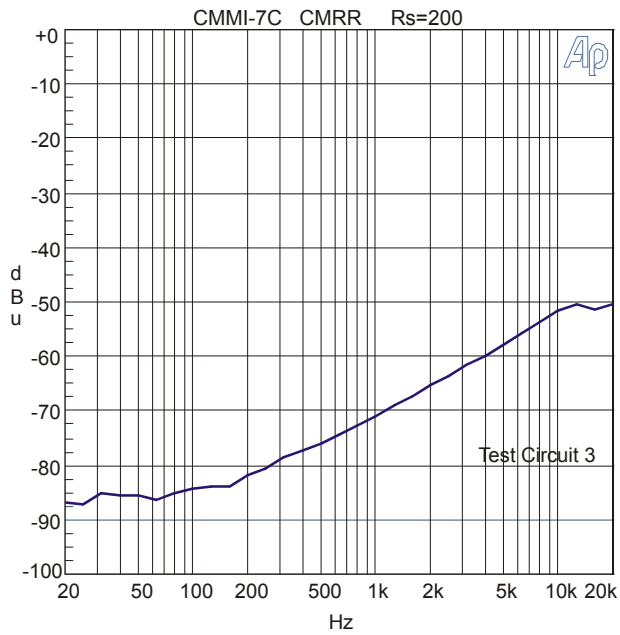

NOTES:

1. All graphs generated from one (1) randomly chosen device. No statistical averaging or weighting. Data from one sweep.

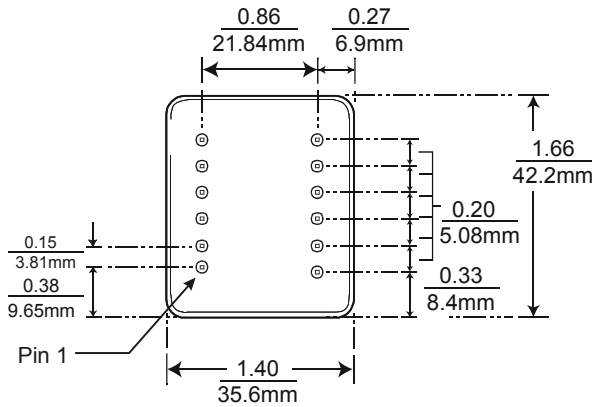
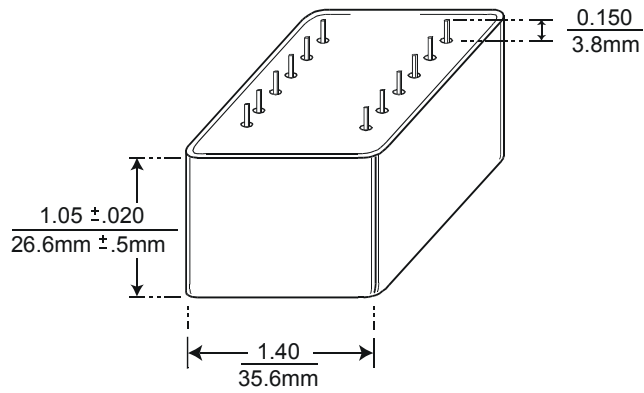
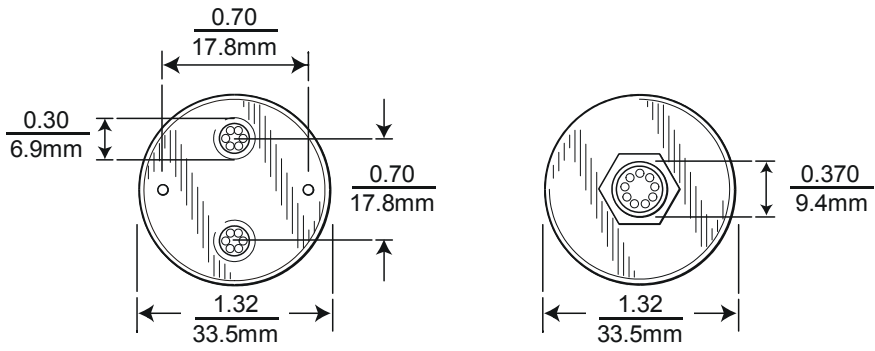
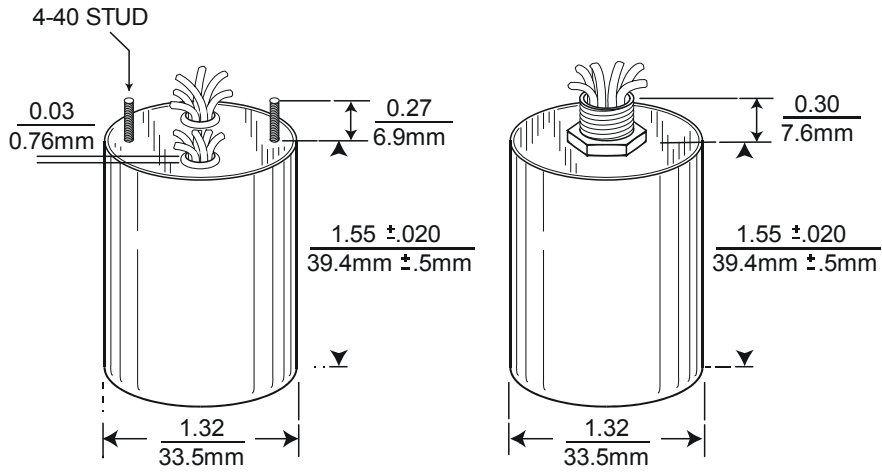

BOTTOM VIEW